

PORTABLE DRUM DUMPER

750/1,000/2,000 LBS

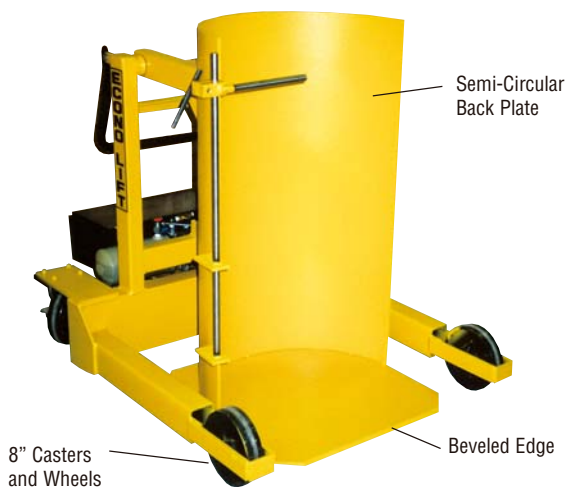

CAPACITY

- 750/ 1,000/ 2,000 lbs.

DUMP HEIGHTS

- 36", 48", 60"

BACKPLATE DIAMETER

- 24"

PLATFORM SIZE

- 24" x 24"

CASTERS/ WHEELS

- 8" dia. x 2" wide

RETAINING BAR

- Fixed
- Adjustable

SAFETY

- Velocity fuse (in case of hose failure it will stop unit from coming down)
- Down flow control - built into power pack, (pressure compensated)
- Heavy duty floor lock

POWER OPTIONS

A/C 110 volt 1/1/60

Hand held pendant (standard)

A/C 230/460/575/3/60 power
Optional

Air/Hydraulic

Foot control (standard)

Hand held pendant (optional)

OPTIONS

- Increase/decrease: platform, diameter of backplate, dump height, tilt angle
- Chute attachments
- Fixed retaining bars
- Stainless Steel
- Galvanized
- "Steel-it" epoxy finish paint
- Limit switches
- "V" groove back plate

OPTIONS

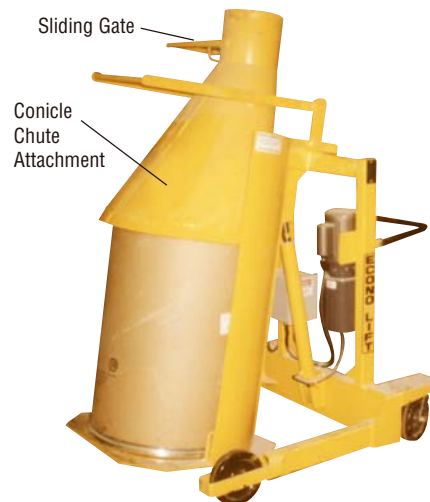

MODEL NO.	CAPACITY (LBS.)	DUMP HEIGHT (IN.)	CHUTE REACH (IN.)	BACKPLATE DIAMETER (IN.)	DUMP ANGLE (DEGREES)	EXTENDED OVERHEAD HEIGHT (IN.)	OVERALL DIMENSIONS (W x L)(IN.)	SHIPPING WEIGHT (LBS)
PDD36-7.5	750	36	7	24	0-120	80	36 x 47	625
PDD36-10	1,000	36	7	24	0-120	80	36 x 47	675
PDD36-20	2,000	36	7	24	0-120	80	36 x 47	800
PDD48-7.5	750	48	8	24	0-120	102	36 x 51	650
PDD48-10	1,000	48	8	24	0-120	102	36 x 51	700
PDD48-20	2,000	48	8	24	0-120	102	36 x 51	850
PDD60-7.5	750	60	8	24	0-120	124	36 x 59	690
PDD60-10	1,000	60	8	24	0-120	124	36 x 59	750
PDD60-20	2,000	60	8	24	0-120	124	36 x 59	900